

REPUBLIC OF **Fritz Hansen**®

DROP™



The Drop™ chair was designed by Arne Jacobsen in 1958 as part of his masterpiece, the legendary SAS Royal Hotel in Copenhagen. The Drop was originally produced along with the Swan™ and the Egg™ but in a very limited number exclusively for the hotel. After more than 50 years in hibernation, the Drop is now relaunched. It is a small chair with a big personality and it is as fresh and vibrant as a new design but with a rare heritage. The design of the back combines a warm embrace with freedom of movement, resulting in a surprising level of comfort.



ARNE JACOBSEN 1902-1971

The cooperation between Arne Jacobsen and Fritz Hansen dates back to 1934. But it was in 1952 the break-through came with the Ant™. It was succeeded by the Series 7™ in 1955. This propelled his and Fritz Hansen's names into furniture history.

Arne Jacobsen was very productive both as an architect and as a designer. At the end of the 50's Arne Jacobsen designed the SAS Royal Hotel in Copenhagen and for that project also the Egg™, the Swan™, the Swan Sofa™ and Series 3300™.

Arne Jacobsen was and is an admired and outstanding designer. While the significance of Arne Jacobsen's buildings was less appreciated, his furniture and other design work have become national and international heritage.



DESIGN

Arne Jacobsen, 1958.

DESCRIPTION

Chair designed by Arne Jacobsen, manufactured by Fritz Hansen.

The shell is made in plastic in comes a selection of colours as well as with upholstery in fabric and leather. The shell is made of ABS plastic with nylon as reinforcement inside. The upholstered chair is upholstered with cold cured foam and covered with fabric or leather.

The base consists of four legs in chromed or powder coated steel tubes. The powder coated legs are only available for the plastic chair in colours matching the shell. The chromed and powder coated base for the plastic chair is with leg ferrules of black synthetic material. On the upholstered chair the base has a chromed steel glide made in one piece with the legs - underneath felt glides are mounted.

The accessories for the chair include a seat cushion for the plastic version and felt glides.

VARIATIONS & DIMENSIONS*

The Drop™ is available with a plastic shell in the colours White, Black, Storm blue, Stone grey, Burgundy Red, Shadow Grey as well as with fabric and leather upholstery.

Seat height: 46 cm / 18.1"
Total height: 88,5 cm / 34.8"
Width: 45,5 cm / 17.9"
Depth: 54,5 cm / 21.5"

ENVIRONMENT & TESTS

In the case of disposal the chair can be disassembled into two parts (shell and legs) for recycling and special handling. The shell of the plastic chair can be re-used. The foam in the shell of the upholstered chair can be granulated and re-used. The legs and all other metal parts can be recycled.

The chair will be tested according to: Functional tests: EN 15373:2007 Non domestic seating – Strength, durability and stability - Test Level 2. Fire tests: Upholstered versions can be configured for compliance of; CAL TB1 17 (for the US market) BS 5852 (for the UK domestic market).

WARRANTY

Standard goods have warranty for five years against manufacturing defects (i.e. materials and design). The warranty does not cover leather and other fabrics ordered as customer own or special material as well as products manufactured according to customer specifications. Normal wear and tear and damage of covers are not covered by the warranty. The warranty for wicker is 2 years.

EXTENDED LIMITED WARRANTY

Fritz Hansen offers an extended limited warranty if you register your Drop™ chair online at fritzhansen.com/MY-REPUBLIC.

Registration with the product ID number must be made within three (3) months from the date of purchase, otherwise the extended limited warranty will not apply.

Years of warranty:

5 years cover: Lacquered base, Fabric, Leather: Basic.

10 years cover: Base, Shell, Leather: Classic, Rustic, Natural, White, Optical white, Elegance, Sense.

UPHOLSTERY

The upholstery is available in the fabrics: Fame, Fame Hybrid, Diablo, Remix, Canvas, Hot, Tonus, Tonus Meadow, Hallingdal, Divina, Divina MD, Divina Melange, Steelcut, Steelcut Trio, Milani and Comfort. The leather includes: Basic, Classic, Rustic, Natural, White, Optical white, Elegance and Sense.

The seat cushion is available in fabrics matching the colours of the plastic shell. The colours/fabrics are:

WHITE

Divina Melange 120



BLACK

Divina Melange 180



STORM BLUE

Divina 171

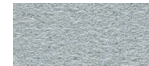

STONE GREY

Divina 944

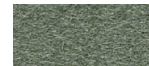



DROP™ - 3110

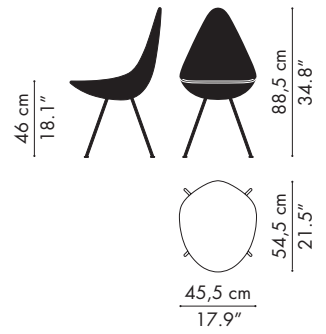

*For upholstered version add approx. Height: 10mm/0,4", Width+Depth: 15mm/0,6".

Fritz Hansen A/S® - This documentation and the products and designations therein are protected by law, including the Danish Copyright Act, Trademark Act and Marketing Practices Act, and may not be used without prior written authority from Fritz Hansen A/S. Legal proceedings may be instituted against any parties breaching the rights of Fritz Hansen A/S.

HEADQUARTERS

Fritz Hansen A/S
Allerødvej 8
DK-3450 Allerød
Denmark

Tel +45 48 17 23 00
Fax +45 69 80 40 20



FRITZHANSEN.COM